



CCT Six - P

User Manual

Rev 10, 02/11/21
Stock code 2003-0076

IMPORTANT NOTE

To comply with EN 1789, the patient body harness and leg straps **MUST** be used at all times to hold the patient on the trolley and the trolley **MUST** be secured in the vehicle with the 2-part locking device.

1. Intended Use of CCT Six-P

The CCT Six-P is intended for use by fully qualified, trained and competent carers, attendants, paramedics or other such medical staff as an aid to provide safe and secure transportation of patients.

The CCT Six-P is a fixed height trolley and its intended use is for the transportation of critically ill patients. The CCT Six-P also provides the facility and storage for ancillary equipment on a fixed base tray and drawers.

WARNING – Although the CCT Six-P is designed to fit into a vehicle that has a Ferno CEN two-part locking device provided for securing the Ferno Falcon Six Trolley it should be noted that the CCT Six-P’s fixed height is higher than that of the Falcon transport height. Furthermore, the stability of the trolley within the locking device could be affected by the addition of care equipment; this equipment should be equally spaced about the trolley, whenever possible.

Combining different manufacturers’ products into a “mixed-component” trolley/fastener system can increase the user’s risk of injury and damage if not checked first for compatibility.

However, Ferno trolleys are designed to be compatible with either the Ferno range of Two-part locking devices or competitors equivalent locking devices, giving you full compatibility and interchangeability across your fleet.

Contact Details

Ferno (UK) Ltd.
Ferno House, Stubs Beck Lane,
Cleckheaton, West Yorkshire, BD19 4TZ
United Kingdom
+44 (0) 1274 851999

Ferno S.R.L.
Via B. Zallone n.26,
40066 Pieve di Cento, Bologna
Italy
+39 051 6860028

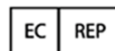

2. Technical Data

Product Name	CCT Six-P
Overall Length	1925 mm
Overall Width	535 mm
Height (Excluding Mattress)	765 mm
Weight (Excluding Mattress & Restraints)	67 kg (dependant on configuration)

Max weight capacity:

Patient platform total max SWL including PacRac (10kg) + equipment (max 25kg), if fitted	181 kg
---	--------

In addition 80kg of medical equipment can be mounted equally spaced on the trolley base.

If foot-end Fixed platform fitted, then 40kg on trolley base and 40kg on foot-end platform.

Total Gross Mass not to exceed 430 Kg (Patient + Equipment + Trolley)

<u>Construction Materials</u>	Powder Coated Steel Aluminium Tubing Aluminium Castings Plastic Injection Mouldings
-------------------------------	--

3. Checking the trolley

The following checks are recommended before the start of each shift's use of the Ferno Trolley.

1. Does the trolley have a properly installed mattress and patient restraining system? Check the mattress for damage; if any damage is found, it must be replaced.
2. Do the trolley sides raise and lower properly?
3. Check that the wheels and brakes operate satisfactorily.
4. Study this manual before use. Practice without a patient until totally competent in using the trolley.
5. Any additional equipment should be checked in accordance with the manufacturers' instructions.

Once these checks have been completed, then the trolley is ready to be used in regular service.

Important Notes

There is no mandatory standard for a Critical Care Trolley, but Ferno (UK) Ltd have taken the initiative to test the unit in accordance with BS EN 1789, which is considered as 'best practice' for safety within ambulance transport.

We can confirm that provided the unit is locked into the Ferno two-part locking device the trolley retention will meet the requirements of this standard.

Always ensure that two operators are with the trolley at all times.

It is advised when rolling the trolley along hospital corridors or similar smooth surfaces, roll the trolley by firmly grasping the main frame, for added control.

Trapping hazards cannot be eliminated due to the operation of this product. EXTRA CARE to be taken whilst raising and lowering the back rest, operating leg rest features and any features with hinge assemblies.

REFER TO PAGES 7 & 8 IF USING PRODUCT WITH 2-PART TRACK-MOUNTED FLOOR LOCK

This product must be regularly serviced and maintained in line with the manufacturer's recommendation to ensure satisfactory operation. A preventative maintenance scheme should be contracted at time of purchase. Regular cleaning helps reduce the risk of transmitting disease and enables the equipment to function at its optimum.

PLEASE NOTE

Cot Sides are not intended to be used to either manoeuvre or lift the trolley, damage may result from this practice.

4. Operating Procedure

WARNING

Always ensure that two trained personnel are with the trolley at all times

Ensure that the following procedures are complied with:

1. Advise the patient before making adjustments.
2. Stay with the patient and control the trolley at all times.
3. Keep the patient restrained and the side rails up when using the trolley.
4. Use help when needed to ensure patient and operator safety.

Transferring a Patient onto the Trolley

1. Lower the cot side rails.
2. Place the trolley beside the patient and open the restraints.
3. Ensure that both brakes are applied.
4. Transfer the patient onto the trolley using recognised manual handling procedures.
5. Close the restraints around the patient (see page 9).
6. Raise the cot side rails.
7. Make adjustments as necessary.

Wheeling the Trolley

1. Transporting a patient should be done with the side rails raised and the harness and restraining straps fastened (see page 9).
2. The trolley is best rolled by two attendants, one pulling and the other assisting with guidance and steering as necessary.
3. If low obstacles (such as door sills) are encountered, roll up to them squarely and lift the leading wheels over the obstacle. Repeat for the trailing wheels.
4. High obstacles should be recognised as potentially hazardous to smooth rolling and trolley balance and may require physical assistance or an alternative route.
5. Ensure that the harness and restraints are fastened around the patient (see page 9).
6. The cot sides are provided for patient safety and must not be used for lifting or manoeuvring the stretcher.

4. Operating Procedure

Loading the trolley into a vehicle fitted with ramps

1. Make sure that the patient is secure at all times whilst on the trolley.
2. The trolley is loaded with the patient's head towards the front of the ambulance.
3. Position the trolley at the base of the ramp, head end first.
4. With the operator at the head end pulling and the operator at the foot end pushing simultaneously, the trolley can now be advanced into the vehicle.

Manual Foot End Lock

5. Ensure that the pedal on the foot end lock is depressed and guide the trolley into the head end floor lock. The foot end will automatically lock when the trolley is in the correct position.

Unloading the trolley from a vehicle fitted with ramps

1. Make sure that the patient is disconnected from any vehicle mounted apparatus or instrumentation.
2. Operation by a minimum of two operators at all times.
3. Disengage the trolley from the two-part locking device by depressing the foot pedal (manual lock) and roll the trolley to the rear of the ambulance compartment.
4. Using two operators guide the trolley down the ramp and out of the vehicle.

4. Operating Procedure

Loading the trolley into a vehicle fitted with a tail lift

1. Make sure that the patient is secure at all times whilst on the trolley.
2. The trolley is loaded with the patient's head towards the front of the ambulance.
3. Guide the trolley on to the tail lift, head end first.
4. Operate the tail lift as per manufacturer's instructions.

Manual Foot End Lock

5. Ensure that the pedal on the foot end lock is depressed and guide the trolley into the head end floor lock. The foot end will automatically lock when the trolley is in the correct position.

Unloading the trolley from a vehicle fitted with a tail lift

1. Make sure that the patient is disconnected from any vehicle mounted apparatus or instrumentation.
2. Operation by a minimum of two operators at all times.
3. Disengage the trolley from the two-part locking device by depressing the foot pedal (manual lock) and roll the trolley to the rear of the ambulance compartment.
4. Guide the trolley onto the tail lift and out of the vehicle.

<p style="text-align: center;">IMPORTANT NOTE</p>
--

<p style="text-align: center;">Ensure the stretcher is secure at all times when on board the tail lift</p>

2-part Track-Mounted Floor Lock (255-mm Gauge NMI System)

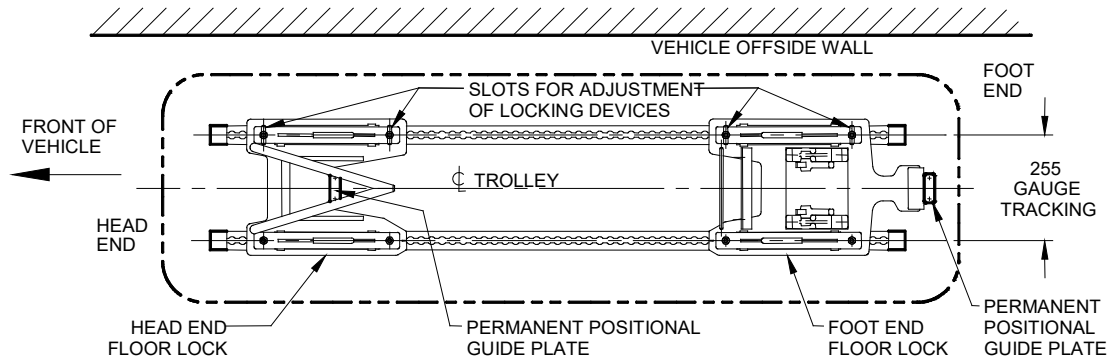

1. Removal of Head End and Foot End Lock Assemblies

- On each locking assembly, undo the conical locking devices then retract the plunger and pull up release handle and blade of both locking devices.
- Remove lock assemblies.
- The small positional guide plates at the head end and foot end must remain fitted to the floor of the vehicle.

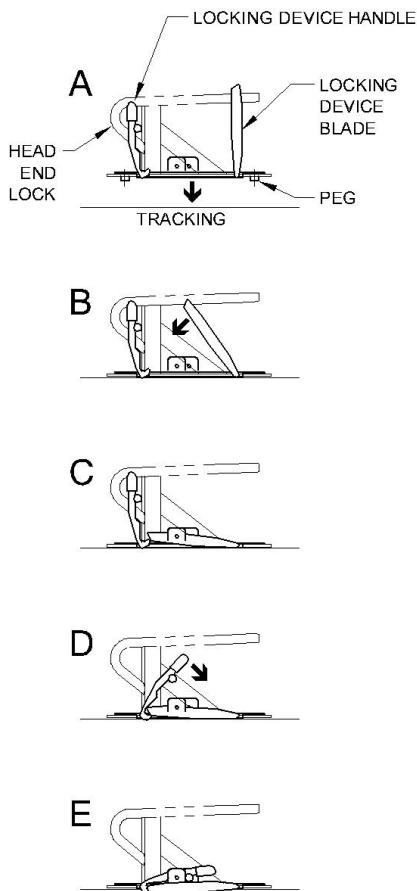

2. Installation of Head End Lock Assembly

- As shown in diagram **A** (left), ensure handle and blade of locking devices are in the fully open (up) position.
- Adjacent to the positional guide plate fitted to the vehicle floor between the tracking at the head end, locate the pegs on the underside of the lock assembly in the tracking.
- As shown in diagrams **B & C**, push blade of each locking mechanism down by hand until it stops.
- Push handle of each locking mechanism fully down (diagram **D**) until the integral plunger locks into place (diagram **E**).
- Re-tighten the conical locking devices, test for security & safety.

3. Installation of Foot End Lock Assembly

Install foot end lock assembly in exactly the same way as above adjacent to the positional guide plate at the foot end.

2-Part Track-Mounted Floor Lock (255-mm Gauge Unwin System)

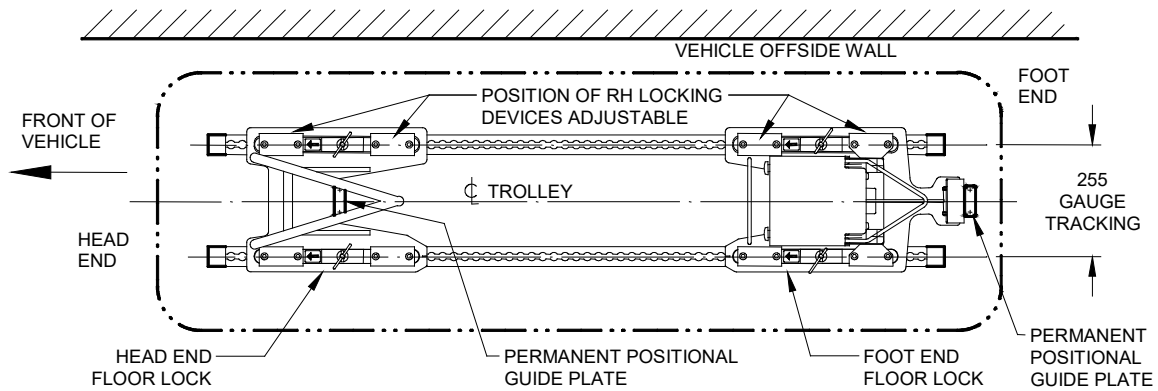

1 Removal of Head End and Foot End Lock Assemblies

- On each Unwin locking device, rotate the plunger crossbar and turret anticlockwise a quarter of a turn. Lift the plunger crossbar from its U-slot in the turret and rotate it slightly to rest it on top of the turret.
- Remove the assembly from the tracking by sliding the assembly along the track half a hole pitch (12-13 mm) and lifting clear.

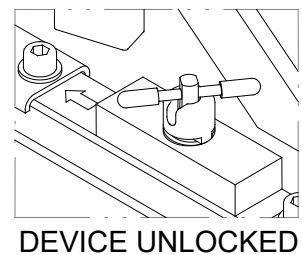

2 Installation of Head End Lock Assembly

- On each Unwin locking device, rotate the plunger crossbar until it snaps into the U-slot on the turret (diagram **A** below). Do not rotate the turret clockwise at this stage.
- Close to the positional guide plate fitted to the vehicle floor between the tracking at the head end, engage the pegs on the underside of the lock assembly in the tracking (diagram **B**).
- Slide the assembly towards its required position until both plungers locate in the track.
- For each of the two Unwin devices, use the plunger crossbar to rotate the turret clockwise a quarter of a turn (diagram **C**). The assembly will be locked rigidly to the tracking.
- Test for security and safety.

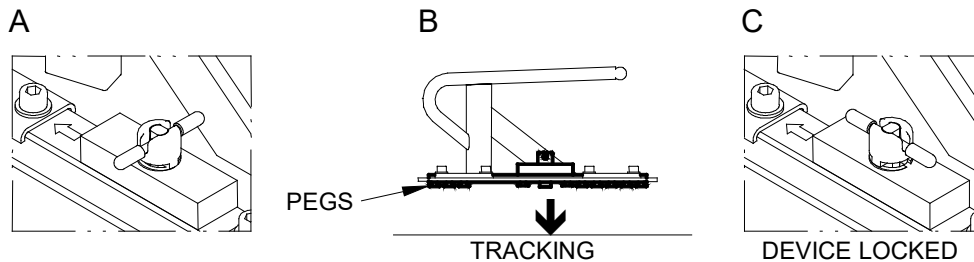

3 Installation of Foot End Lock Assembly

Install foot end lock assembly in exactly the same way as above adjacent to the positional guide plate at the foot end.

4. Operating Procedure

Using the Restraints

1. The patient should be secured using the harness and both single strap restraints.
2. Dispose of and replace any restraints that are worn, damaged or have been involved in any accident – they may have hidden damage.
3. Unbuckle all restraints and lay the straps out of the way before transferring the patient.
4. Transfer the patient onto the trolley using recognised techniques.
5. Buckle the harness by inserting all three tangs into the buckle until they lock in place or pass the tang through the shoulder straps and secure in the buckle. Adjust the straps to ensure patient comfort.
6. Fasten the one-piece restraint across the patient's chest and under the arms (if fitted).
7. Fasten the two leg restraints and adjust to ensure patient comfort.
8. To release the harness, twist the buckle lever or depress the buckle release.

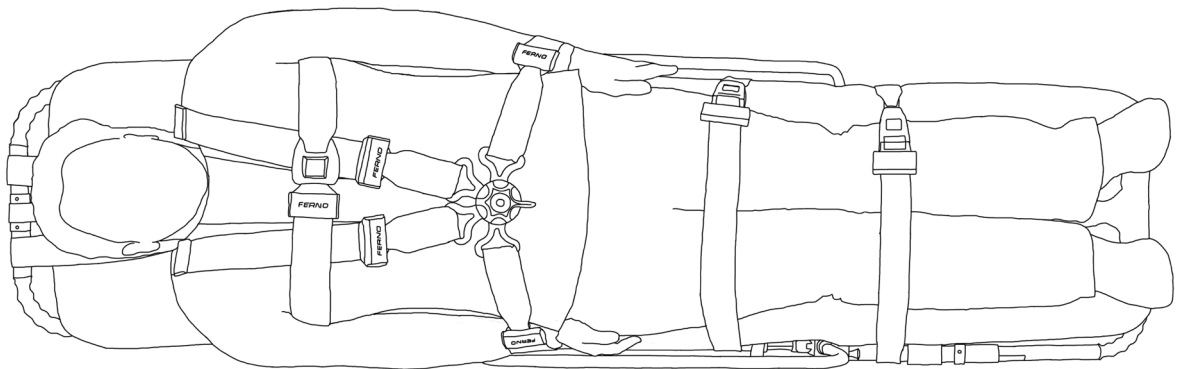

Illustration purposes only.

NOTE

To remove the four-point harness, unclip all four brackets from mounting pegs.

5. Trolley Features

Restraints

Each trolley is equipped with a 4-point harness and two restraint straps, **all of which should be used at all times**. The harness is secured to the trolley locating posts with hooks, and each strap has loops so that they can be easily attached to the trolley frame.

Cot Sides

Cot sides should always be used when the patient has been placed on the trolley. These can be lowered by pulling out the lock pin. All cot sides lock automatically when raised to the vertical position.

PLEASE NOTE

Cot sides are not intended to be used to either manoeuvre or lift the trolley, damage may result from this practice.

Backrest

The backrest may be locked in any inclined position. Support the backrest frame with one hand (to avoid sudden movement). Squeeze the control lever with the other hand. Raise the backrest to the desired angle and release the lever to lock it in position. Support the backrest while making adjustments. The backrest also incorporates superior support for CPR. **DO NOT** use the backrest to manoeuvre the stretcher under any circumstances. When using the stretcher as a seat in a PTS vehicle ensure the headrest is in its lowest position.

Headrest

The CCT Six-P is provided with a detachable headrest that affords support particularly in the patient seated position. The black push button, located at the top of the backrest, allows the fitting and removal of the headrest, which can be rotated through half a turn to provide either a cup shape head support or flat support to incorporate a pillow. A vehicle CEN tested stowage bracket, for the headrest, is also available.

Storage

A shelving system may be provided for the stowage of equipment or patient personal effects, together with tray space alongside.

Wheels

All wheels have a braking system ensuring that the castor wheel will not turn when the brake lever is applied. The brake should be engaged whenever a patient is being transferred onto or off the trolley.

5. Trolley Features

Leg Rest Features

The following features must be executed with the operator positioned at the foot end of the trolley.

Trendelenburg Position

To raise the leg rest to the Trendelenburg position, grip and support the leg rest frame at the foot end. Lift the leg rest until the support bar locks into position. Maintain a grip on the frame and gradually reduce support of the leg rest until you are confident that the support bar has locked.

To lower the leg rest from the Trendelenburg position, hold the leg rest frame at both sides **at the foot end**. Slide hands forward until fingers contact the support bar on the underside of the leg rest frame. At this point, simultaneously lift and move the support bar forward, thus releasing same from its locked position and slowly lower the leg rest frame to its resting position.

NOTE:

Potential pinch point - care should be taken during operation

Knee Contour (Fowler) Position

To raise the knee contour position, hold both lifting straps (yellow) and lift up. Gradually release the lifting straps, ensuring that the support bar has locked in position. This procedure may be performed more easily with the cot sides lowered.

To lower the knee contour position, hold both release straps (red), lift up and pull straps in the direction of the foot end and slowly lower the frame to its resting position.

NOTE:

Potential pinch point - care should be taken during operation

6. Servicing, Cleaning and Maintenance

Servicing and Maintenance Schedule

It is recommended to set up and follow a routine maintenance schedule at regular intervals, which should be carried out at least once a year.

The table below represents recommended minimum intervals for such maintenance as well as recommended intervals for cleaning, disinfecting and general inspection.

Ensure to keep service records. A sample maintenance record sheet is provided at the end of this manual, which can be used to log each maintenance service.

When documented service can be shown to have been followed and an audit trail implemented, your organisation will be demonstrating a commitment to patient safety and safety procedures.

This Service Schedule has been created to provide protection for the patient and users of this equipment.

Failure to take the correct measures may have serious consequences.

Minimum Maintenance Intervals	Each Use	As Needed	Each Month	Yearly
Disinfecting	•			
Cleaning		•		
Inspecting		•	•	•
Lubricating		•		
Maintenance Service				•

Cleaning, Disinfecting & Maintenance

Regular cleaning helps reduce the risk of transmitting disease and enables equipment to function at its optimum.

Ensure that all equipment is removed from the trolley and that the Power distribution socket is disconnected from mains supply.

Trolley should be hand-wiped using a suitable cleaning solution. For particularly grimy cases, especially if the trolley has been in storage for a long period, it may be necessary to first clean the trolley with a water-soluble solvent-soaked cloth.

Once cleaned, dry the trolley with a soft towel, paying particular attention to swivel and sliding joints. If a compressed air hose is available, you may find that compressed air jets are more effective in drying the hard-to-reach places.

Ensure no liquid enters the power distribution sockets.

Cleaning webbing restraint straps

1. Immerse the restraint webbing straps in a solution of mild soap and water. Do not immerse any metal buckles or metal fixation clips in the solution, these should be wiped clean only.

2. Repeatedly dip the webbing in clear water to rinse. Do not immerse any metal buckles or fixation clips

3. Hang the restraints to air-dry. Attach only clean, dry restraints back onto to the equipment

Disinfecting webbing restraint straps

1. Immerse or spray the restraint webbing straps following the selected disinfectant manufacturer's instructions for application method and contact time. Do not immerse any metal buckles or metal fixation clips into disinfectant liquid

2. Spray the metal buckles and fixation clips with disinfectant cleaner spray, following the disinfectant manufacturer's instructions for application method and contact time

3. Hang the restraints to air-dry if needed. Attach only dried restraints to the equipment

Cleaning Biosafe restraint straps

1. Wipe-clean the restraints, buckles and fixing clips with mild soap and water

2. Hang the restraints to air-dry. Attach only clean, dry restraints back onto to the equipment

Disinfecting Biosafe restraint straps

1. Spray the restraint webbing metal buckles and fixation clips with disinfectant cleaner spray, following the disinfectant manufacturer's instructions for application method and contact time

2. Hang the restraints to air-dry if needed. Attach only dried restraints to the equipment

Safe Decontamination of Equipment

It is also suggested to disinfect your Trolley at regular intervals to maximise infection control. Where body fluids or blood are suspected of being present, wash down the unit after use, using a germicidal detergent adequate for inactivating HIV and the HBV virus.

Adequate protective clothing must be worn, to protect yourself and others from hazards present in a typical workshop environment.

- Safety Glasses/Goggles or Full-Face Protector
- Dust/Vapour Protector Mask
- Rubber/Leather Gloves
- Clinical Waste Disposal Container

It is recommended that disinfectant that is not chlorine, phenolic or iodine-based is used to disinfect equipment as these chemicals can cause surface damage with regular use and contact, especially on certain materials and metal finishes such as anodizing, zinc plating etc.

If these type of disinfectants are to be used, then to minimise the level of damage they will cause it is recommended that they are used with the least possible contact time, diluted as specified by the manufacturer's guidelines, and that the equipment is then thoroughly washed down with water after disinfecting in order to remove any chemical residue and prevent any ongoing surface damage from occurring.

Any attachable accessories should be cleaned/disinfected whilst detached from the trolley. For example, trolley push poles should be removed from the corner sockets before both the trolley and poles are cleaned and disinfected, and everything then thoroughly washed down with water.

Following these guidelines will ensure effective disinfecting whilst minimising any long-term damage and keeping equipment in good operable condition.

Trolley maintenance lubrication

Your Ferno CCT trolley will work efficiently and safely only when it is well lubricated. You **MUST** lubricate all moving and sliding parts after every inspection or preventative maintenance programme, or if there is inadequate lubrication for the moving parts to operate easily and quietly.

In general terms, almost all sliding and moving parts may be lubricated with a light duty grease. A penetrating fluid lubrication is used on some sliding parts of the trolley. However, when a penetrating fluid lubricant is used, all excess **MUST** be wiped away, to prevent any build-up of dust or grime, which can clog up working parts and impede movement.

Ferno Trolley General Inspection Checklist

- Check that the trolley has a properly installed mattress and complete set of patient restraints (upper body and legs)
- Are all other components and accessories present?
- Is the trolley generally free of excessive wear?
- Are all screws, nuts, bolts and rivets securely in place?
- Do all moving parts operate smoothly and properly?
- Do the wheel castors and brake operate properly, rotate fully and have adequate tread?
- Does the trolley move smoothly?
- Are the restraints, mattress and harness in good condition with no cuts or frayed edges? If not, then they must be replaced
- Are restraint buckles free of visible damage and do they operate properly?
- Check that the trolley cot sides raise, lower and lock in position
- Check operation of the backrest and leg-raise platforms
- Check the operation of the push/pull handles and any accessories
- Check that the ambulance has a properly installed, approved locking device and that the trolley locks in securely

FernoCare Maintenance & service contracts

As the manufacturer of this equipment, Ferno UK offer a cost-effective servicing programme, helping to keep your equipment in good condition and keeping whole life time costs to a minimum.

- FernoCare service technicians are dedicated to providing quality equipment service and repair
- To minimise down time, Ferno service vehicles are fully equipped with all replacement parts
- All FernoCare Service Technicians wear official identity badges and uniforms
- Emergency Call out - Whatever your location, Ferno have field-based Technicians located throughout the UK

Service Contracts

- FernoCare provide competitively priced service and inspection contracts
- We offer a discount if a Ferno Service contract is taken out, you only pay once the service has been completed
- Additional discounts can be offered if a 5-year contract is taken out, with a guarantee to hold the price for the effective contract period
- Pay annually or as the service is completed, helping you to control your costs
- A service report is provided for each piece of equipment, detailing parts that may have required replacement and also its condition
- These documents provide an audit trail and can be presented with your service schedule for equipment inspection purposes

Warranty

Ferno (UK) Ltd. standard terms and conditions apply to all sales. A copy is available on request. These contain full details of warranty terms and do not limit the statutory rights of the customer.

Contact information

For questions on service, maintenance and any other questions regarding this or any other Ferno product, please contact:

Ferno (UK) Limited
Ferno House
Stubs Beck Lane
Cleckheaton
West Yorkshire
England
BD19 4TZ

Telephone Main Reception: +44 (0) 1274 851999
Telephone Service Dept: +44 (0) 1274 854511
Email Service Dept: services@ferno.co.uk
Internet: www.ferno.co.uk

The manufacturer below hereby declares that the medical device, or the Technical documentation, specified in this User Manual is Dual marked for sale on both the UK and EU markets. The Class I Medical Device covered by this User Manual complies with the General Safety and Performance Requirements within *Annex-1* of EC Regulation 2017/745

Registered Office:

Ferno (UK) Limited
Ferno House, Stubs Beck Lane, Cleckheaton, West Yorkshire, England. BD19 4TZ
Tel: + 44 (0) 1274 851999
Email: services@ferno.co.uk / sales@ferno.co.uk
www.ferno.co.uk

Registered number: 1007475 England

As our policy is one of continuous development Ferno (UK) Ltd reserves the right to change the specifications without notice.

Stock Code: 2003-0076